

VALVCHEQ BACKFLOW PREVENTERS

FIGURE DCDA03

Double check detector assembly for medium hazard rated applications
Flanged and roll grooved end connections

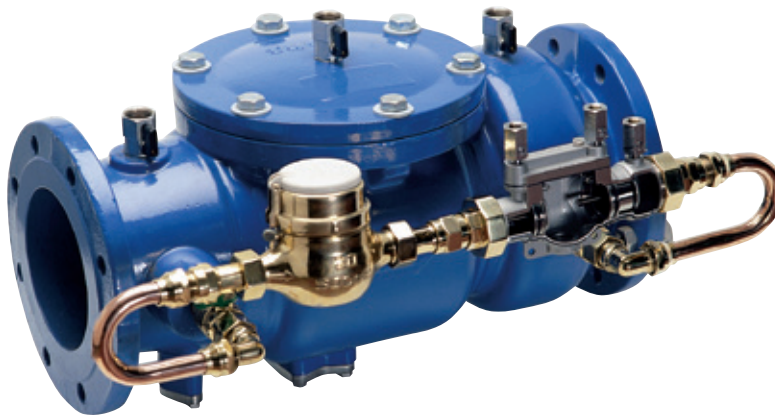

FEATURES

- Compact simple design.
- In-line and on-site serviceable.
- No special tools required for servicing.
- Designed and manufactured in accordance with AS/NZS 2845.1.
- FBE coated to AS/NZS 4158.
- Straight through flow path for maximum flow co-efficient.
- By-pass lines have lockable ball valves for security.
- Lifting lugs to assist with installation.
- Top entry allows all parts to be accessed easily.
- Stainless steel internals for superior corrosion resistance.
- Fully restrained check valve assemblies for unrivalled safety.
- Each valve is bench tested and tracked with unique serial number.
- All internal components are repairable or replaceable.
- All internal and external bolting is stainless steel.
- Conforms to testing requirements of AS/NZS 2845.3.
- Design conforms to all major international standards.
- Installations can be vertical and horizontal.
- Full bore by-pass line connection for maximum flow:
 - 40mm for valve sizes DN 65 and 80.
 - 50mm for valve sizes DN 100 and 150.

GENERAL APPLICATION

The DCDA03 provides protection from both backsiphonage and backpressure of the potable water supply from contamination in medium hazard applications. The metered by-pass monitors low flows, including leak detection and illegal use of fire lines.

TECHNICAL DATA

Size range: DN 65 -150
 Temperature rating: 1°C to 60°C
 Working pressure: PN16
 End connections: Flanged AS 4087
 Roll grooved AS 2638
 Alternative flange drillings may be available on request



AS/NZS 2845.1 Lic WMKA 1324
SAI Global

VALVCEO BACKFLOW PREVENTERS

FIGURE DCDA03

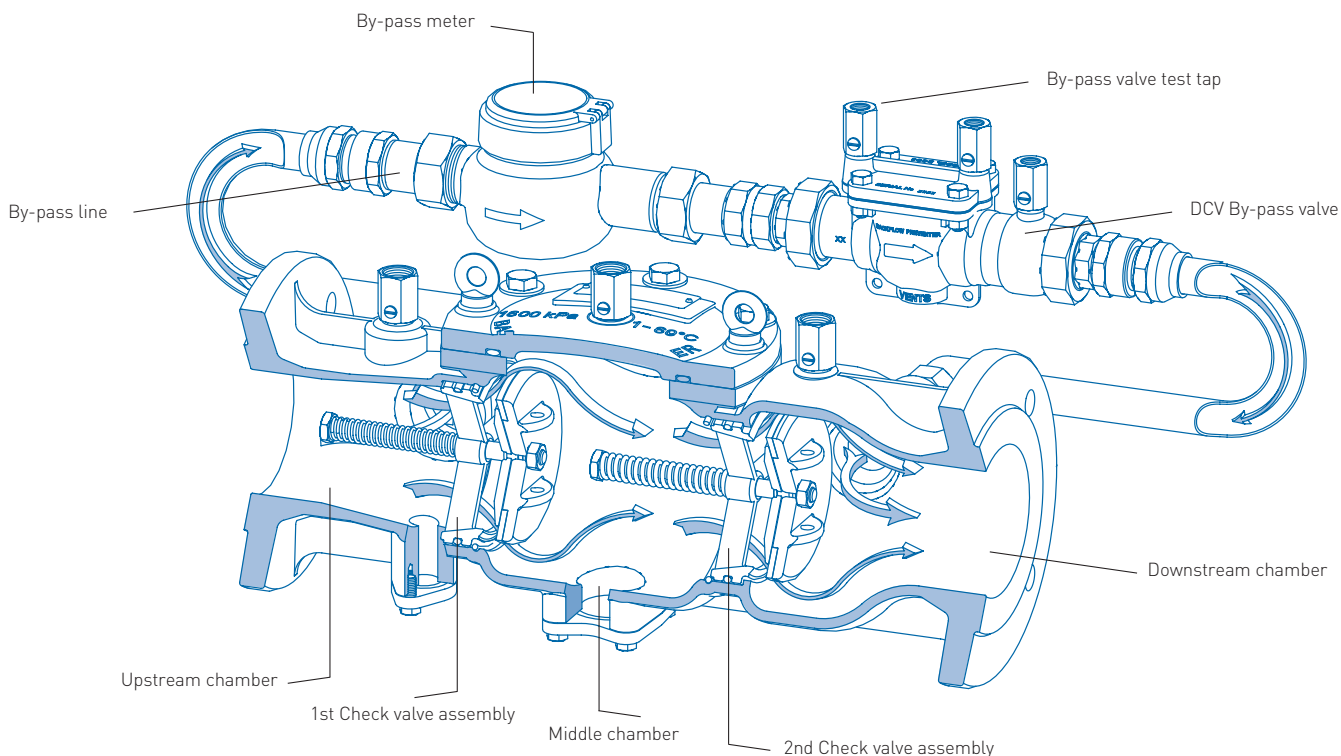

PRINCIPLE OF OPERATION

All detector assemblies are installed in applications to monitor low flows resulting from leaks or illegal use of the fire system.

Under low flow dynamic conditions:

Pressure builds up in the upstream chamber before 1st check valve assembly of the main valve. The 1st check valve assembly has a minimum holding pressure of 20 kPa higher than by-pass valve. Therefore; flow is diverted through the by-pass and the minor valve operates as normal with each check assembly opening at a pressure of 7 kPa. The water meter in the by-pass line monitors the amount of water used during low flow periods.

For high demand:

(When fighting a fire)

The by-pass line cannot deliver required demand causing pressure to build in the upstream chamber before 1st check valve assembly of the main valve. When there is sufficient pressure (min of 35 kPa) the main valve check assemblies will open and deliver full flow.

Under backpressure condition:

(Premises pressure is greater than supply pressure)

Water pressure in downstream chamber and spring pressure force the 2nd check valve assemblies closed.

Under backsiphonage condition:

(Negative supply pressure in mains supply)

Water pressure in the upstream chamber before the 1st check valve assembly will dissipate and 1st check valve assemblies will close under spring pressure.

VALVCEQ BACKFLOW PREVENTERS

FIGURE DCDA03

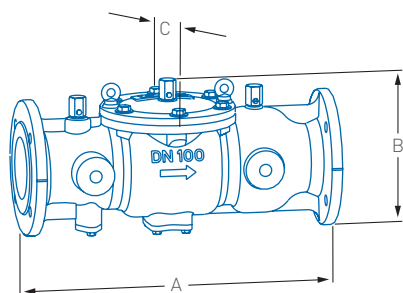

Note: Valve only (VO) illustrated.

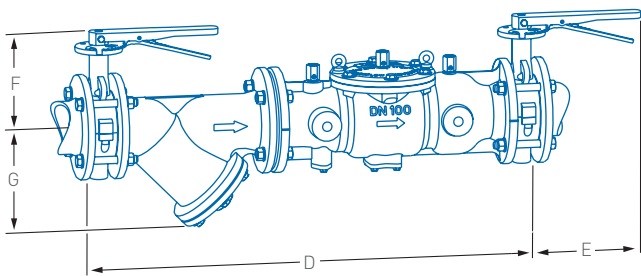

Note: Butterfly valve (BFV) arrangement illustrated.

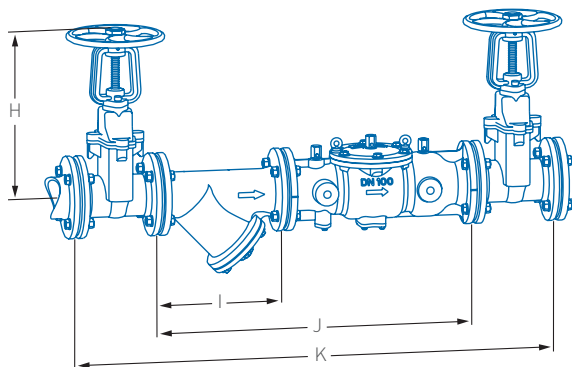

Note: Resilient seated gate (RSGV) valve arrangement illustrated.

NOTE

- VO = Mass of valve only.
- BFV = Mass of complete arrangement with butterfly valves.
- RSGV = Mass of complete arrangement with resilient seated gate valves.

DIMENSIONS (mm)

Valve size DN	A	B	C	D	E	F	G	H	I	J	K	Mass (kg)		
												VO	BFV	RSGV
65	400	335	185	778	240	180	177	-	283	686	-	21	43.4	-
80	400	335	185	810	240	190	210	367	315	718	1130	21	49.2	72
100	535	382	230	1012	240	210	235	402	370	908	1372	38	78.4	138
150	685	480	300	1310	240	230	390	502	510	1198	1738	76	149.0	232

NOTE

Dimension are nominal to ± 1 mm.
 Butterfly valve actuators change from handles to gear operators on valve sizes DN 200 and above.
 Gear operation actuators available on request for butterfly valve arrangement.
 Lockable actuators available on request.

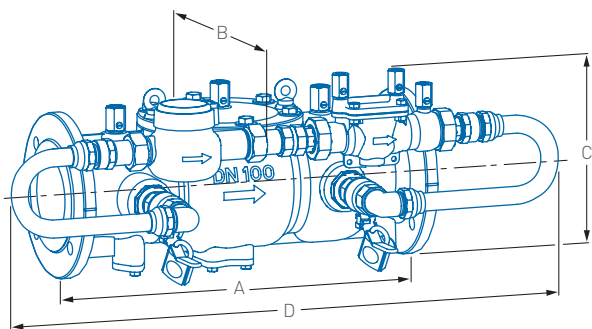

Note: Valve only with by-pass illustrated.

DIMENSIONS (mm)

Valve size DN	A	B	C	D (by-pass)					Mass (kg)
				20	25	32	40	50	
65	400	380	250	750	850	950	1000	1100	21
80	400	380	250	750	850	950	1000	1100	21
100	535	467	310	750	850	950	1000	1100	38
150	685	570	550	750	850	950	1000	1100	76

NOTE

Dimensions are nominal to ± 1 mm.
 Mass is of the DCDA unit only.

VALVCEQ BACKFLOW PREVENTERS

FIGURE DCDA03

TYPICAL FLOW CHARACTERISTIC GRAPHS

DN 65 AND 80

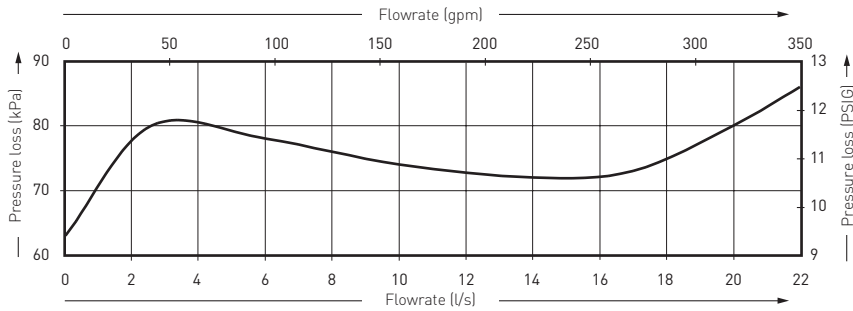

DN 100

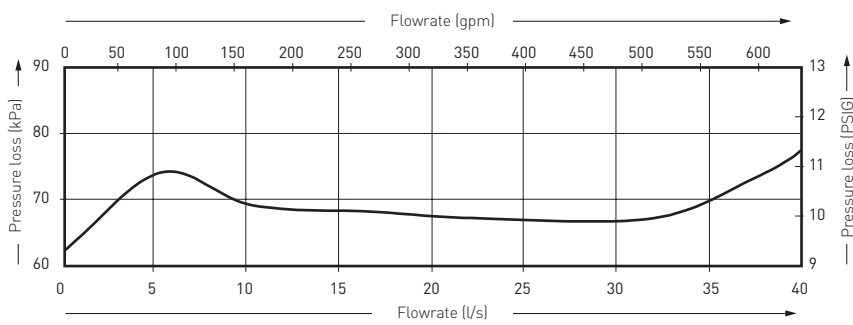

DN 150

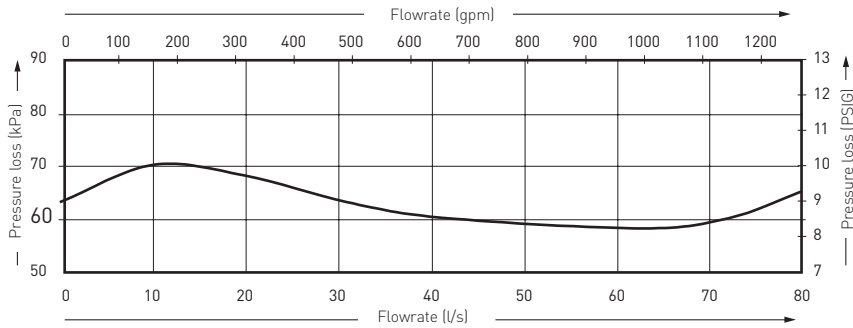

Maximum by-pass flow rates before main valve opens

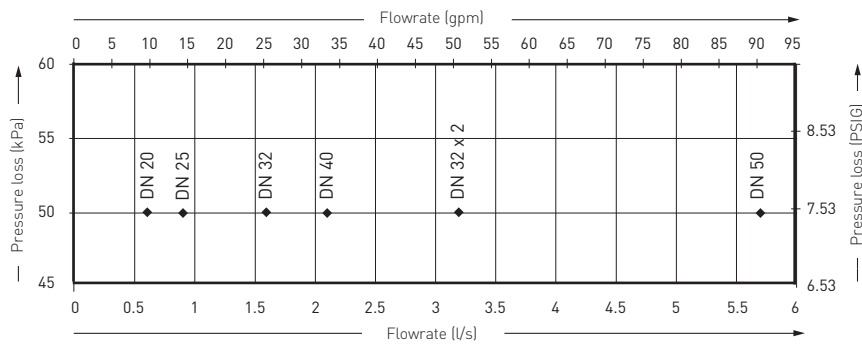

VALVCEQ BACKFLOW PREVENTERS

FIGURE DCDA03

TROUBLESHOOTING - Main valve

Symptom	Cause	Remedy
1st check valve not holding tight (reading approaches zero without holding)	<ol style="list-style-type: none"> 1. Debris fouling the check valve seal 2. Check valve seal damaged or perished 3. Check valve O-ring damaged 4. Check valve stem O-ring damaged 5. Check valve seal ring damaged 	<ol style="list-style-type: none"> 1. Inspect, clean, reverse or replace check seal 2. Inspect and replace check valve seal 3. Inspect and replace O-ring 4. Inspect and replace O-ring 5. Replace first check valve assembly
1st check valve holding below 7 kPa	<ol style="list-style-type: none"> 1. Debris fouling the check valve seal 2. Check valve seal damaged 3. Check valve spring memory loss or damaged 4. Check valve stem O-ring damaged 	<ol style="list-style-type: none"> 1. Inspect, clean, reverse or replace check seal 2. Inspect and replace check valve seal 3. Replace first check valve assembly 4. Inspect and replace O-ring
2nd check valve not holding tight (reading approaches zero without holding)	<ol style="list-style-type: none"> 1. Debris fouling the check valve seal 2. Check valve seal damaged or perished 3. Check valve O-ring damaged 4. Check valve stem O-ring damaged 5. Check valve seal ring damaged 	<ol style="list-style-type: none"> 1. Inspect and clean, reverse or replace check seal 2. Inspect and replace check valve seal 3. Inspect and replace O-ring 4. Inspect and replace O-ring 5. Replace second check valve assembly
2nd check valve not holding 20 kPa differential above by-pass valve	<ol style="list-style-type: none"> 1. Debris fouling the check valve seal 2. Check valve seal damaged 3. Check valve spring memory loss or damaged 4. Check valve stem O-ring damaged 	<ol style="list-style-type: none"> 1. Inspect, clean, reverse or replace check seal 2. Inspect and replace check valve seal 3. Replace second check valve assembly 4. Inspect and replace O-ring

TROUBLESHOOTING - By-pass valve

Symptom	Cause	Remedy
1st check valve not holding tight (reading approaches zero without holding)	<ol style="list-style-type: none"> 1. Debris fouling the check valve seal 2. Check valve seal damaged or perished 3. Check valve O-ring damaged 4. Check valve seal ring damaged. 5. Check valve stem O-ring damaged. 	<ol style="list-style-type: none"> 1. Inspect, clean, reverse or replace check seal 2. Inspect and replace check valve seal 3. Inspect and replace O-ring 4. Replace first check valve assembly. 5. Inspect and replace O-ring.
1st check valve holding below 7 kPa	<ol style="list-style-type: none"> 1. Debris fouling the check valve seal 2. Check valve seal damaged 3. Check valve spring memory loss or damaged 4. Check valve stem O-ring damaged 	<ol style="list-style-type: none"> 1. Inspect, clean, reverse or replace check seal 2. Inspect and replace check valve seal 3. Replace first check valve assembly 4. Inspect and replace O-ring
2nd check valve not holding tight (reading approaches zero without holding)	<ol style="list-style-type: none"> 1. Debris fouling the check valve seal 2. Check valve seal damaged or perished 3. Check valve O-ring damaged 4. Check valve stem O-ring damaged 5. Check valve seal ring damaged 	<ol style="list-style-type: none"> 1. Inspect and clean, reverse or replace check seal 2. Inspect and replace check valve seal 3. Inspect and replace O-ring 4. Inspect and replace O-ring 5. Replace second check valve assembly
2nd check valve holding below 7 kPa	<ol style="list-style-type: none"> 1. Debris fouling the check valve seal 2. Check valve seal damaged 3. Check valve spring memory loss or damaged 4. Check valve stem O-ring damaged 	<ol style="list-style-type: none"> 1. Inspect, clean, reverse or replace check seal 2. Inspect and replace check valve seal 3. Replace second check valve assembly 4. Inspect and replace O-ring

VALVCEQ BACKFLOW PREVENTERS

FIGURE DCDA03

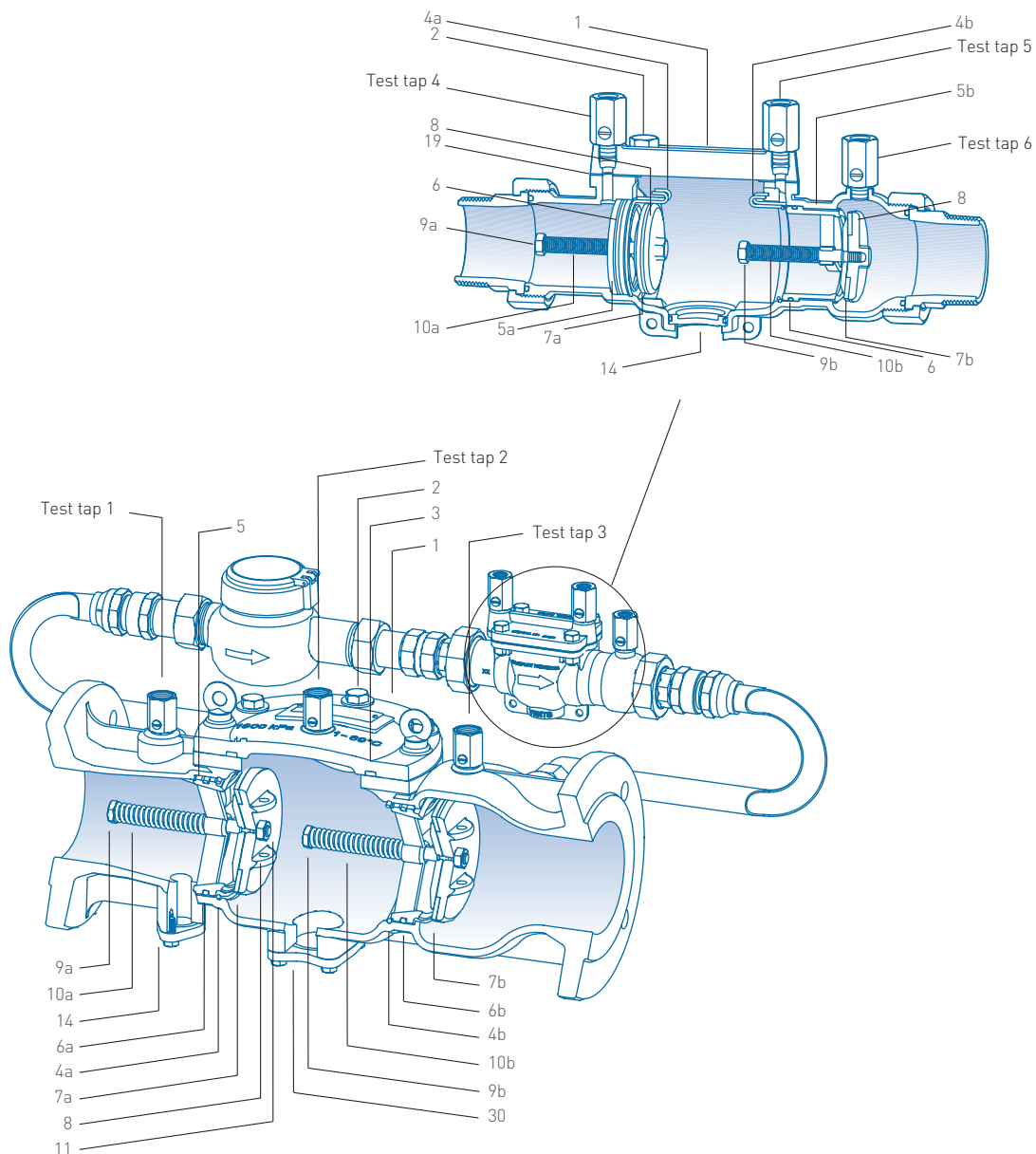

PARTS LIST - Main valve

No.	Description
1	Cover plate
2	Cover plate bolts
3	Cover plate O-ring
4	Check valve circlip
5	Check valve seal ring
6	Check valve O-ring
7	Check valve seal
8	Check valve disc
9	Check valve stem
10	Check valve spring
11	Check valve retaining nut
14	Sensor port plate
30	Relief port plate

PARTS LIST - By-pass valve

No.	Description
1	Cover plate
2	Cover plate bolts
4	Check valve circlip
5	Check valve seal ring
6	Check valve O-ring
7	Check valve seal
8	Check valve disc
9	Check valve stem
10	Check valve spring
14	Sensor port plate
19	Diaphragm

VALVCHQ BACKFLOW PREVENTERS

FIGURE DCDA03

Complete safety and maintenance instructions for double check detector assemblies

MAINTENANCE AND TESTING REQUIREMENTS

Test after initial installation and annually for the life of the valve or service. Maintain in a working order and inspect for operational function at intervals not exceeding twelve months. The functions are to be carried out by authorized licensed backflow testers.

DISASSEMBLY INSTRUCTIONS

Main valve

As per safety precautions slowly close isolation valves and the open test taps 1, 2 and 3 to exhaust line pressure.

Remove cover plate bolts (2) and washers. Remove cover plate (1) and cover plate O-ring (3) With a screwdriver remove 2nd check valve assembly circlip (4b) utilizing cavity recess in the body casting.

NOTE

Please take care and do not chip FBE coating with screwdriver.

To remove 2nd check valve assembly pull check valve stem/spring (9b and 10b) out and then up bringing the check assembly through the top entry of the valve.

With a screwdriver remove 1st check valve assembly circlip (4a) utilizing cavity recess in the body casting.

NOTE

Please take care and do not chip FBE coating with screwdriver.

To remove 1st check valve assembly take a screwdriver and lever the assembly out by utilizing lugs provided on check valve disc (8a). Pull check valve assembly out and then up through the top entry of the valve.

Both check valve disc (8) assemblies are mechanically the same, please use the following steps to access check valve seals (7a and 7b).

Using two spanners, fit one spanners to the check valve stem head (9) and the other to the check valve retaining nut (11), turn check valve retaining nut anti-clockwise and remove.

Remove check valve disc (8), to expose the check valve seal (7) for servicing or replacement.

By-pass valve

As described in the safety precautions slowly close isolation valves and the open test taps 4, 5 and 6 to exhaust line pressure.

Remove cover plate bolts (2) and washers. Remove cover plate (1) and diaphragm (19).

Check valve assemblies

Utilizing both sets of circlip prongs, squeeze together and pull out 1st and 2nd check valve assembly circlips (4a and 4b). To remove 2nd check valve assembly pull check valve stem/spring (9b and 10b) out, then upwards through the top entry of the valve.

To remove 1st check valve assembly, very slowly and carefully just crack open inlet isolating valve to allow the water pressure to push the check valve assembly into the intermediate chamber.

Or conversely; by utilizing a pair of pliers on check valve disc hex (8). Shut off the inlet isolating valve and remove the check valve assembly through the top entry of the valve.

Both check valve assemblies are mechanically the same, please use the following steps to access check valve seals (7a and 7b).

Using two spanners, fit one spanner to the check valve stem head (9) and the other to the check valve disc (8), turn check disc anticlockwise and remove.

Remove check valve disc (8), to expose them for servicing or replacement.

NOTE

When reassembling:

- Lubricate all O-rings.
- 2nd check valve assembly has the longer body (5b).

Check valve seal (7) and relief diaphragm (19) must be clean, free of any greases, moisture and debris to ensure a positive seal.

SAFETY PRECAUTIONS

In every instance of installation or removal from the pipeline, ensure the line is not pressurized and any hazardous liquid is drained away.

Slowly close both isolating valves and then open test tap 1 through 6 to exhaust line pressure then close test taps on the bypass double check valve.

VALVCEQ BACKFLOW PREVENTERS

FIGURE DCDA03

SELECTION GUIDE

Example:	100	DCDA03	C	x 25
Valve size DN				
Figure no.				
End connections				
RG	Roll grooved AS 2638			
C	Flanged AS 4087 Table C			
	Alternative flange drillings may be available on request			
Options				
Single by-pass line	Double by-pass line	Spacer by-pass line (no meter)		
x 20 c/w meter	x 20 x 2 c/w meters	x 20 spacer		
x 25 c/w meter	x 25 x 2 c/w meters	x 25 spacer		
x 32 c/w meter	x 32 x 2 c/w meters	x 32 spacer		
x 40 c/w meter	x 40 x 2 c/w meters	x 40 spacer		
x 50 c/w meter	x 50 x 2 c/w meters	x 50 spacer		

NOTE

Double by-pass available in DN 100 and DN 150 valve assemblies.
All Emerson isolation valves come with the provision for locking.

Recommended specifications for double check valves for medium hazard rated applications



- Both main valve and by-pass valve shall be manufactured in accordance with AS/NZS 2845.1.
- Main valve shall be ductile iron FBE coated to AS/NZS 4158.
- Main valve internals shall be constructed from stainless steel and to have pressure rating of PN16 and a temperature rating of 60°C.
- Main valve body shall not form part of the wetted check valve sealing area or mechanism.
- All internal components and elastomer seals shall be accessible through a top entry point of the main valve to allow inline maintenance.
- Main valve to have flanged connections that conform to AS 4087 or roll groove that conforms to AS 2638.
- By-pass valves DN 20 to DN 50 to be BSP screwed to AS 1722.
- By-pass valve and internals shall be of stainless steel construction and to have pressure rating of PN16 and a temperature rating of 90°C.
- Threaded by-pass connection shall be a minimum of 40mm for DN 80 main valves and a minimum of 50mm for DN 100 and DN 150 main valves.
- Valve test points shall also be fitted with BSPT threads to allow testing to AS/NZS 2845.3.